

# Effect of n-pentanol addition on the combustion, performance and emission characteristics of a direct-injection diesel engine



Liangjie Wei<sup>a,b</sup>, C.S. Cheung<sup>a,\*</sup>, Zuohua Huang<sup>b</sup>

<sup>a</sup> Department of Mechanical Engineering, The Hong Kong Polytechnic University, Hung Hom, Kowloon, Hong Kong

<sup>b</sup> State Key Laboratory of Multiphase Flow in Power Engineering, Xi'an Jiaotong University, Xi'an 710049, PR China

## ARTICLE INFO

### Article history:

Received 19 April 2013

Received in revised form

18 March 2014

Accepted 24 March 2014

Available online 29 April 2014

### Keywords:

Pentanol

Second-generation biofuel

Combustion

Gaseous emissions

Particle emissions

Diesel engine

## ABSTRACT

In this study, experiments were conducted to examine the effect of using a mixture of diesel and n-pentanol, which is one of the second-generation biofuels with comparable properties to diesel fuel, as fuel on the combustion, performance, and gaseous and particulate emissions of a naturally-aspirated, four-cylinder, direct-injection diesel engine. Three n-pentanol fractions in the fuel mixture were selected: 10, 20 and 30% by volume. Results show that, the addition of n-pentanol leads to longer ignition delay and increases the peak heat release rate in the premixed combustion phase. The brake specific fuel consumption increases with increase of n-pentanol, while the brake thermal efficiency is not affected. Regarding the gaseous emissions, n-pentanol addition results in the following consequence: (a) HC (hydrocarbon) and CO (carbon monoxide) emissions increase for 30% n-pentanol in the blended fuel at low engine load but decrease at high engine load; (b) a slight increase (maximum 8%) in NO<sub>x</sub> emissions but noticeable increase in NO<sub>2</sub> emissions. Regarding the particulate emissions, n-pentanol is found to be very promising in terms of reducing both the mass concentration and the particulate number concentration simultaneously.

© 2014 Elsevier Ltd. All rights reserved.

## 1. Introduction

The increasing use of internal combustion engines has led to the problems of depletion of fossil fuel and increasing stringent regulations on particulate emissions. Different approaches to relief these problems on diesel engines have been explored, including the use of alternative fuels. Oxygenate biofuels, such as bio-alcohols, can be produced from a variety of non-food biomass, such as forest wood feedbacks, agricultural residual and marine algae through the biochemical conversion process [1,2]. Additionally, oxygenated additives have been shown to reduce the particulate emission [3–5]. Thus bio-alcohols have the potential to be a substitution for the traditional diesel fuel. Among the bio-alcohols, ethanol has been widely studied as additives on both spark-ignition engines [6–9] and compression-ignition engines [10–17]. The results showed that the particulate emission is decreased for the ethanol–diesel blends. However, when ethanol is added into diesel fuel, several critical issues arise. Specifically, ethanol has poor miscibility with diesel fuel and it possesses a 40% lower volumetric energy density

than that of diesel fuel. Also, the cetane number of ethanol is much lower than that of diesel fuel, as can be seen from Table 1, thus, cetane number improver may be required [18]. Furthermore, because of its lower flashpoint, boiling point and viscosity, ethanol causes problems of safe storage and lubricity of fuel supply system [18,19]. Thus recently, investigations on higher chain alcohols, such as butanols (C4 alcohols), have received much interest. Butanols can mix well with diesel fuel [20,21], and its energy density, cetane number, viscosity, flashpoint and boiling point are all higher compared with those of ethanol. Thus a lot of work has recently been conducted on investigating the fundamental combustion and kinetic models of butanols [22–25]. Engine tests have also been extensively conducted on using butanols as neat fuels or as fuel additives [21,26–31].

n-Pentanol is a 5-carbon structure straight-chain alcohol with even higher energy density and cetane number comparing with butanol. The properties of n-pentanol are presented also in Table 1. It is seen that its physical properties are similar to those of diesel fuel, such that, it is likely to be a more attractive additive to diesel fuel, among all the alcohols [27]. Recently, mass production of n-pentanol has been investigated. For instance, biosynthesis of pentanol from glucose or glycerol is achieved by employing the metabolic engineering of novel biocatalysts [32–34]. To gain

\* Corresponding author. Tel.: +852 2766 7819; fax: +852 2365 4703.  
E-mail address: [mmcsc@polyu.edu.hk](mailto:mmcsc@polyu.edu.hk) (C.S. Cheung).

**Table 1**  
Properties of diesel, n-pentanol, n-butanol and ethanol [41,42,56,57].

Fuel properties	Diesel	n-Pentanol	n-Butanol	Ethanol
Cetane number	52	20	17	8
Lower heating value [MJ kg <sup>-1</sup> ]	42.5	34.65	33.09	26.83
Density at 20 °C [kg m <sup>-3</sup> ]	827	814	810	788
Viscosity at 40 °C [mm <sup>2</sup> s <sup>-1</sup> ]	2.86	2.88	2.22	1.13
Vaporization latent heat [kJ kg <sup>-1</sup> ]	250–290	308	585	918
Flashpoint [°C]	71	49	35	14
Boiling point [°C]	210–235	138	117	79
C/H mass ratio	6.46	4.96	4.77	3.97
Oxygen content [wt.%]	0	18.1	21.6	34.7
Sulfur content [mg kg <sup>-1</sup> ]	<10	0	0	0

deeper insight into the fundamental combustion of pentanol isomers, especially regarding the chemical kinetic aspect, several experimental and modeling works had been conducted recently [35–40]. Significantly less work, however, has been conducted by using pentanol as a neat fuel or a fuel additive on internal combustion engines. Gautam et al. [41,42] studied the emission and combustion characteristics of higher alcohols blended with gasoline on a spark-ignition engine, and their results showed that addition of higher alcohols reduced the brake specific emissions, because of the increased knock resistance. Campos-Fernández et al. [27,43] investigated the performance of a diesel engine fueled with n-butanol/diesel and n-pentanol/diesel blends. The results showed that, without modification of the engine, up to 25% n-pentanol addition to diesel fuel yielded no adverse effect on the engine combustion. However, they did not collect the emission data when the engine was fueled with n-pentanol/diesel blends. Engine tests using n-pentanol/rapeseed oil blends were carried out by Yoshimoto and Onodera [44] on a diesel engine and they showed that the addition of n-pentanol reduced the viscosity of the blended fuel and might reduce the smoke emission, without any influences on combustion.

The above review shows that there is lack of investigation on the application of n-pentanol to diesel engines, especially on its influence on particulate emissions. The objective of the present work is to examine the potential of n-pentanol as an additive to diesel fuel. Specifically, with up to 30% by volume of n-pentanol in the blended fuel, the engine combustion and performance characteristics, the gaseous emissions such as the unburned hydrocarbons, CO (carbon monoxide), NO<sub>x</sub> and NO<sub>2</sub> emissions, and the particulate emissions in terms of the mass and number concentrations are investigated.

## 2. Experimental setup and approaches

In this work, a naturally-aspirated, four-cylinder, direct-injection diesel engine, which is commonly used in Hong Kong and Chinese mainland, was employed in the experiment. The engine is coupled with an eddy-current dynamometer for measuring and adjusting engine speed and torque with the help of an Ono Sokki heavy-duty diesel engine test system. The specifications of the engine are available in Table 2.

The diesel fuel used in this study has sulfur content lower than 10 mg·kg<sup>-1</sup> and was purchased from Esso Hong Kong. Besides neat diesel fuel, three n-pentanol/diesel blends were prepared at the mixing ratio of 10/90 (DP10), 20/80 (DP20) and 30/70 (DP30) by volume with high purity n-pentanol (purity > 99%). No solvent or cetane improver was added. An oil tank and an electronic balance with accuracy of 0.05% were employed to measure the fuel consumption.

The schematic of the experimental system is shown in Fig. 1. In this work, gaseous and particulate emissions were both investigated. The in-cylinder pressure was sampled by a Kistler pressure

**Table 2**  
Engine specifications.

Engine model	ISUZU 4HF1
Type	In-line 4-cylinder
Maximum power	88 kW@3200 rpm
Maximum torque	285 Nm@1800 rpm
Bore/stroke	112 mm/110 mm
Displacement	4334 cm <sup>3</sup>
Compression ratio	19.0:1
Fuel injection timing	8° BTDC
Injection pump type	Bosch in-line type
Injection nozzle	Hole type (with 5 orifices)

transducer (type 5011B), coupled with a crank-angle encoder (type CA-RIE-720, DEWETRON) with a resolution of 0.5 crankshaft angle. The pressure data were then analyzed by a combustion analyzer (DEWETRON, DEWE-ORION-0816-100x) to obtain the heat release rate. In order to reduce the influence of cycle-by-cycle variation, data of 400 cycles were averaged to obtain the in-cylinder pressure. The gaseous emissions in the engine exhaust were measured on a continuous basis. The total unburned hydrocarbon (HC), nitrogen oxides (NO<sub>x</sub>) and carbon monoxide (CO) were measured with a heated flame ionization detector (HFID), a heated chemiluminescent analyzer (HCLA) and a non-dispersive infra-red analyzer (NDIR), respectively. The gas analyzers were calibrated with standard gases and zero gas before each experiment.

A tapered element oscillating microbalance (TEOM, Series 1105, Rupprecht & Patashnick Co., Inc.) and a scanning mobility particle sizer (SMPS, Model 3071a, TSI, Inc.) were employed for the measurement of particle mass concentration and size-number distribution, respectively, coupled with the Dekati diluters. Dilution ratio was determined from CO<sub>2</sub> concentrations of background air, raw exhaust emission and diluted exhaust emission [45]. Tests were started after the temperatures of the exhaust, the cooling water and the lubricating oil have reached their steady states at each loading condition. Subsequently, the gaseous concentrations and particulate mass concentrations were measured for 5 min continuously, and the average results were presented. Regarding the particle number-size distribution, in each test, four measurements cycle were employed and the average result was presented. Table 3 shows the experimental uncertainties and standard errors of the results. For each test, the steady state tests were repeated at least twice to ensure that the variations were within the experimental uncertainties.

## 3. Results and discussion

Engine tests were performed at five steady loads with brake mean effective pressures (BMEP) of 0.84, 2.06, 4.15, 6.20 and 7.10 bar and at the maximum torque speed of 1800 rpm. Engine combustion and performance characteristics, gaseous emissions including total unburned hydrocarbon, carbon monoxide, nitrogen oxides and nitrogen dioxide, and particulate emissions were presented and discussed in this section. Since there is very few reported work on the use of pentanol as alternative fuel on diesel engine, especially those concerning particulate emissions, explanations for methanol, ethanol or butanol blended with diesel fuel are employed to interpret the results obtained in this work.

### 3.1. Combustion characteristics

The in-cylinder pressure profiles for each fuel at low, medium and high engine loads corresponding to BMEPs of 2.06, 4.15 and 6.20 bar, respectively, are shown in Fig. 2. In general, it is seen that

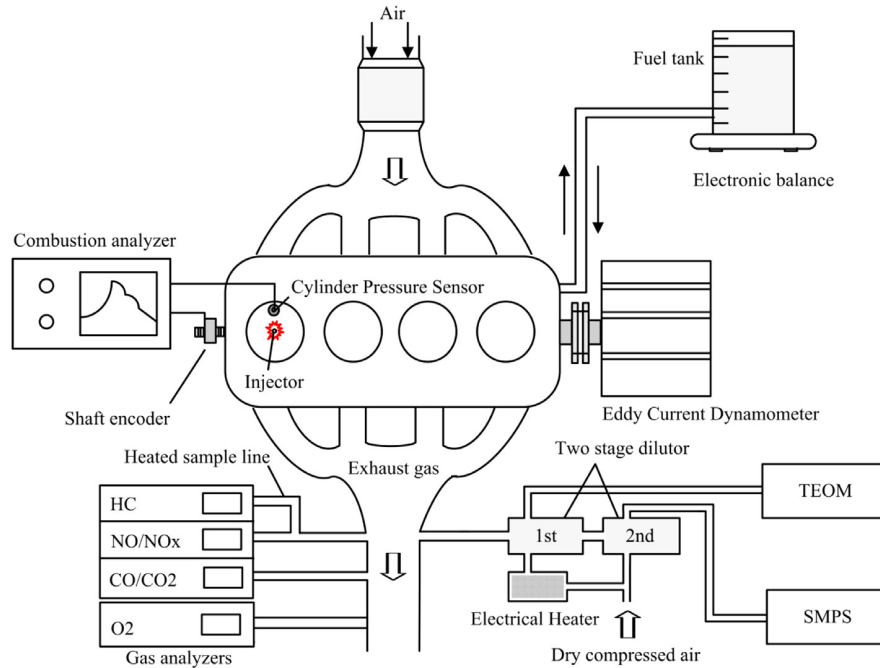

Fig. 1. Schematic of the experimental system.

the peak in-cylinder pressure increases with increasing engine load. Moreover, at each engine load, the pressure profiles of the blended fuels are similar with that of neat diesel fuel, however, the ignition is retarded by the addition of n-pentanol and the ignition delay increases with the increase of n-pentanol in the blended fuel, as listed in Table 5. In this paper, the ignition delay was obtained from the start of fuel injection to the start of combustion, with the later defined as the zero crossing on the heat release rate curve. This is due to the reduction of cetane number for the blended fuel as the cetane number of n-pentanol is lower than that of diesel fuel. At the low engine load, the peak in-cylinder pressure decreases with increasing n-pentanol, whereas it increases with increasing n-pentanol at medium and high engine loads. The slight decrease of peak in-cylinder pressure at low engine load is not statistically significant. At the low load, the addition of pentanol increases the latent heat of evaporation of the fuel and delays the combustion further into the expansion stroke, both of which may reduce peak in-cylinder pressure. However, the increase in ignition delay leads to more fuel being burned in premixed mode, which may lead to increase in peak in-cylinder pressure. The conflicting factors lead to insignificant decrease in the peak in-cylinder pressure with increase of pentanol. However at medium and high engine loads, the higher in-cylinder temperature may weaken the cooling effect of n-pentanol, while the increase in ignition delay increases fuel burned

in the premixed mode, leading to the increase in peak in-cylinder pressure. Also, as shown in Table 5, the crank angle of 50% heat release, indicated by CA50, basically remains unchanged at the engine load of 2.06 bar, whereas it decreases as n-pentanol increases in the blended fuel at engine loads of 4.15 and 6.20 bar, indicating more fuel is burned earlier, leading to the increase in peak in-cylinder pressure at these two engine loads.

Fig. 3 gives the heat release rate for the different fuels at the low, medium and high engine loads. Generally, the heat release curves of the blended fuels are similar with those of neat diesel fuel,

Table 3  
Experimental uncertainty and standard errors.

Parameter	Uncertainty (95% confidence level,%)	Parameter	Standard error (%)
HC	8.7	BSFC	1.0
CO	5.2	BTE	1.0
NO <sub>x</sub>	2.8	PMC <sup>a</sup>	2.3
NO <sub>2</sub>	6.4	TPNC <sup>b</sup>	2.5
		GMD	1.6
		Gas temperature	1.0

<sup>a</sup> Particulate mass concentration.

<sup>b</sup> Total particulate number concentration.

Table 4  
Fuel consumption and engine performance.

Engine Load [bar]	Fuel	BSFC [g kW <sup>-1</sup> h <sup>-1</sup> ]	BTE [%]	$\phi_a$	Exhaust temperature [°C]
0.84	Diesel	478	17.7	6.61	178
	DP10	482	17.9	6.54	175
	DP20	491	17.9	6.53	175
	DP30	508	17.6	6.47	175
2.06	Diesel	289	29.3	4.40	238
	DP10	295	29.3	4.34	235
	DP20	299	29.4	4.36	235
	DP30	308	29.1	4.34	234
4.15	Diesel	234	36.2	2.62	356
	DP10	238	36.2	2.62	355
	DP20	242	36.3	2.64	353
	DP30	248	36.2	2.61	350
6.20	Diesel	226	37.5	1.78	504
	DP10	231	37.4	1.75	500
	DP20	236	37.3	1.79	497
	DP30	238	37.6	1.80	490
7.10	Diesel	231	36.6	1.50	592
	DP10	234	36.9	1.49	587
	DP20	238	36.9	1.51	582
	DP30	247	36.4	1.50	577

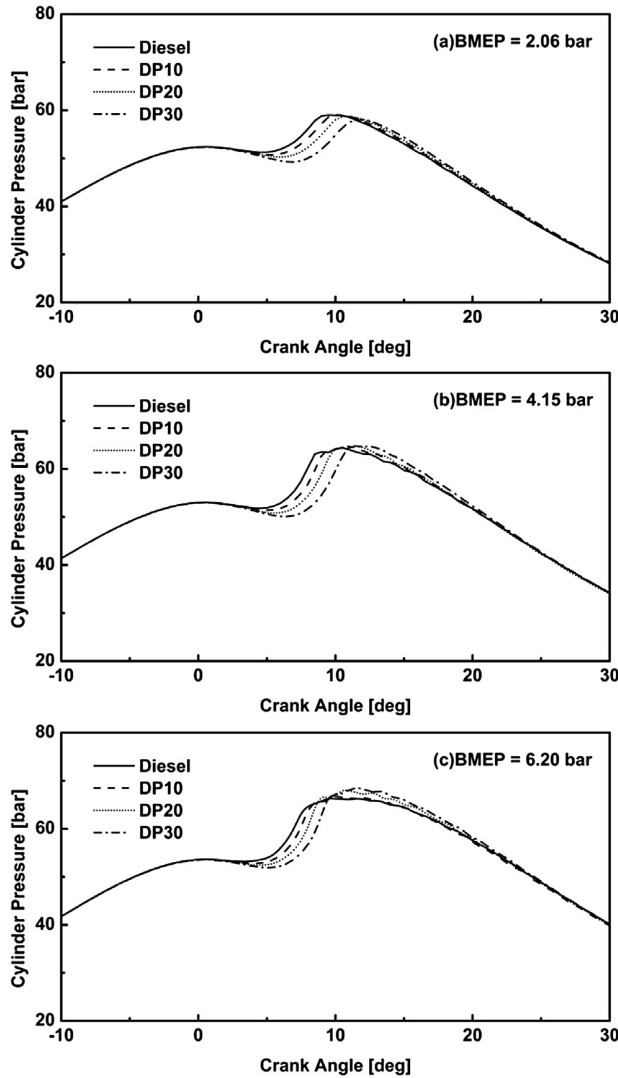

Fig. 2. Variation of in-cylinder pressure profiles with n-pentanol and engine load.

showing a rapid phase of premixed combustion, followed by a slower phase of diffusion combustion. Moreover, the peak heat release rate in the period of premixed combustion increases and the crank angle at which it appears shifts further away from the top-dead-center. The latter one also indicates that the ignition delay is longer for the blended fuels as evidenced by the pressure profiles in Fig. 2. Longer ignition delay for the blended fuel leads to more fuel being burned in the premixed combustion phase, resulting in higher heat release rate. Compared with diesel fuel, the corresponding increases in peak heat release rate at these three

Table 5  
Ignition delay and CA50 at various engine loads and fuel blends.

Fuel	2.05 bar		4.15 bar		6.20 bar	
	Ignition delay [CA]	CA50 [CA]	Ignition delay [CA]	CA50 [CA]	Ignition delay [CA]	CA50 [CA]
Diesel	4.31	11.04	3.75	13.30	2.84	15.88
DP10	4.51	10.95	3.98	13.02	3.04	15.90
DP20	4.89	10.96	4.42	12.65	3.41	15.36
DP30	5.44	11.24	4.97	12.45	3.75	15.21

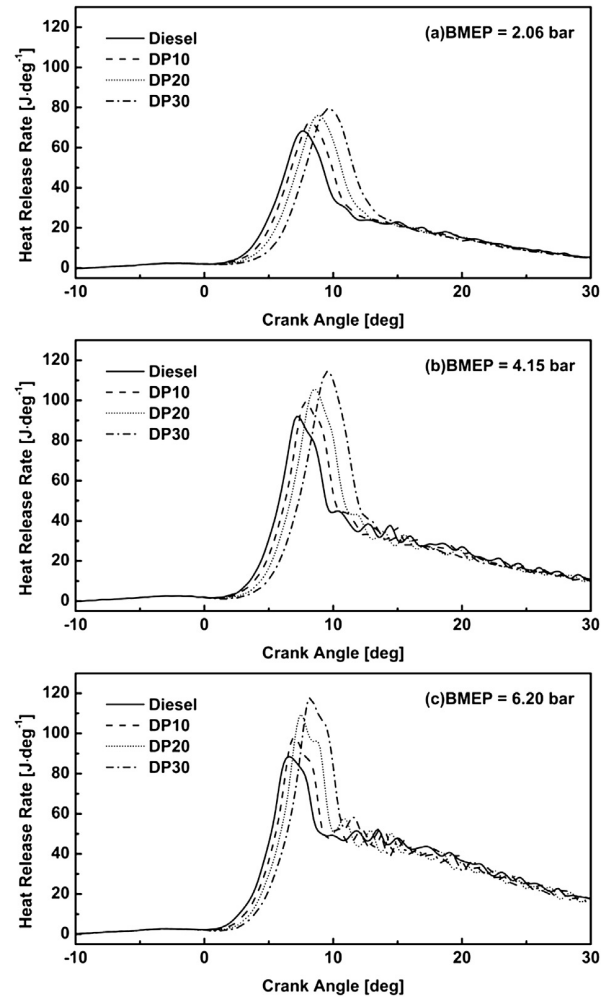

Fig. 3. Variation of heat release rate with n-pentanol and engine load.

engine loads are 5.8–16.5, 9.3–26.7 and 11.1–30.5%, for DP10, DP20 and DP30, respectively. With the increase of engine load, the heat release curves occur closer to the top-dead-center, indicating that the ignition delay becomes shorter as engine load increases, associated with the higher in-cylinder gas temperature. Additionally, the peak heat release rate increases from low to medium engine load for all fuels, however, it decreases at high engine load. This is caused by the reduced fuel being burned in the premixed combustion phase as a result of the shorter ignition delay at higher engine load.

### 3.2. Engine performance

Based on the engine load, the engine speed, measured fuel mass consumption rate and lower heating value of the fuels, the brake specific fuel consumption (BSFC) and brake thermal efficiency (BTE) were calculated and illustrated in Table 4. The excess air ratio is also shown in Table 4. It was calculated based on Ref. [46]. In general, the BSFC decreases with the increase of engine load, but increases slightly at 7.10 bar. Li et al. [13] and Cheung et al. [47] reported similar BSFC trend in ethanol/diesel blends with up to 24% ethanol in diesel fuel. This may be due to the high oil temperature and low excess air ratio at the engine load of 7.10 bar which deteriorate the lubrication and combustion, respectively, leading to the increase in

BSFC. Furthermore, with increasing n-pentanol, the BSFC increases at all five loads. It is expected that due to the lower energy density of n-pentanol in comparison with diesel fuel, more fuel is required to generate a certain power output. It can be observed that the BSFC at 0.84 bar is remarkably higher than that of other loads. For the diesel, DP10, DP20 and DP30, at BMEP of 0.84 bar, the BSFCs are 478, 482, 491 and 508  $\text{g kW}^{-1} \text{h}^{-1}$ , respectively; while the BSFCs are 226, 231, 236 and 238  $\text{g kW}^{-1} \text{h}^{-1}$ , respectively, at 6.20 bar. At low engine load, the in-cylinder gas temperature is relatively low, leading to incomplete and low efficiency combustion, resulting in higher BSFC.

With regard to the BTE, as shown in Table 4, it increases as the engine load increases from 0.84 to 6.20 bar and decreases slightly when the engine load increases from 6.20 to 7.10 bar. At each engine load, there is only a small variation in BTE with increasing n-pentanol, compared with neat diesel fuel. Campos-Fernández et al. [27] found similar results, showing that statistically there is no significant difference between diesel and n-pentanol/diesel blends. The exhaust temperature (shown in Table 4) exhibits a small drop with n-pentanol in diesel fuel, due to the lower calorific value and a higher heat of evaporation of n-pentanol. Similar trend was also observed in other alcohols/diesel blends [47,48].

### 3.3. Gaseous emissions

The total unburned hydrocarbon (HC) emissions for the different fuels are given in Fig. 4. For neat diesel fuel, in general, the HC emissions decrease with increasing engine load. This can be attributed to the higher in-cylinder gas temperature associated with higher engine load. With increasing n-pentanol in diesel fuel, the HC emissions increase except at 7.10 bar. Higher percentage of n-pentanol in the blended fuel leads to higher HC emissions at a given engine load, specifically, at the engine load of 0.84 bar, the HC emissions are respectively 288, 310, 353 and 409 ppm for diesel, DP10, DP20 and DP30. When the engine load approaches 6.20 bar, the difference becomes smaller. The HC emissions increased by 15%, ranging from 212 ppm for diesel to 243 ppm for DP30 at the engine load of 6.20 bar. In the recent work of Rakopoulos et al. [20] conducted on a heavy-duty direct-injection diesel engine, HC emissions were also found to be higher for n-butanol/diesel blends comparing with the neat diesel fuel. They suggested that the higher heat of evaporation and the increasing lean outer flame zone for ethanol–diesel or n-butanol–diesel lead to higher HC emissions. However, this may not be the reason for n-pentanol/diesel. As seen

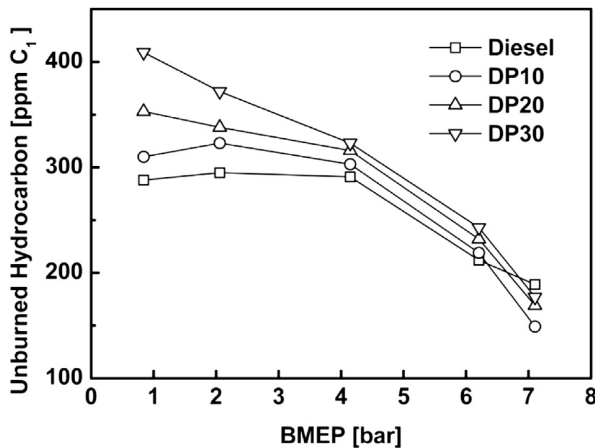

Fig. 4. Variation of total unburned hydrocarbon emissions with n-pentanol and engine load.

in Table 1, the heat of evaporation of n-pentanol is only slightly higher than that of diesel fuel, thus, the heat of vaporization may only have a slight influence on HC emissions. However, the cetane number of n-pentanol is smaller than that of diesel, thus it is expected that n-pentanol/diesel blends have lower cetane number compared with diesel fuel, which results in a longer ignition delay for the blended fuel. As a consequence, there will be more time for the fuel to vaporize, leading to a broader lean outer flame zone, which results in higher HC emissions with the addition of n-pentanol. He et al. [11] and Corkwell et al. [12] found HC emissions sharply decreased with cetane number improver additives and became comparable with that of diesel in ethanol/diesel blends. However, as the engine load increases to 7.10 bar, diesel fuel emits higher HC emissions than that of n-pentanol/diesel blends. Similar results were observed for ethanol/diesel blends, as shown in Ref. [47], and this can be explained by the fact that the oxygen content of the blended fuel increases as n-pentanol is added, which favors the oxidation of unburned hydrocarbon at relatively high in-cylinder temperature.

Fig. 5 shows the variations of carbon monoxide (CO) emissions, which are similar with HC emissions. It can be observed that the CO emissions in general decrease with increasing engine load due to the increased in-cylinder gas temperature. Besides, CO emissions exhibit an increasing trend with increasing n-pentanol except at 7.10 bar. Similar increase in CO emissions was reported in the literatures [10–12,47] for ethanol/diesel blends and attributed to the higher heat of evaporation of ethanol which reduced the in-cylinder gas temperature. However, using cetane number improver, substantial decrease in CO emissions was achieved [11,12]. Consequently, similar to HC emissions, the lower cetane number of n-pentanol plays a dominant role in the increase of CO emissions. Concerning the CO emissions of neat diesel fuel, it exhibits a slight increase from engine load of 6.20–7.10 bar. This may be attributed to the low excess air ratio at the engine load of 7.10 bar, as shown in Table 4. However, the presence of n-pentanol provides higher local oxygen concentration which helps in reducing the CO emissions.

The effect of n-pentanol addition on nitrogen oxides ( $\text{NO}_x$ ) emissions is given in Fig. 6. In general,  $\text{NO}_x$  emissions increases with the engine load for all n-pentanol/diesel blends as well as for diesel fuel. It is expected that the in-cylinder gas temperature increases with the increase of engine load, leading to higher  $\text{NO}_x$  emissions. Comparing with diesel fuel,  $\text{NO}_x$  emissions of n-pentanol/diesel blends show no noticeable difference at low engine load. However, as engine load increasing, slight increase can be observed for n-

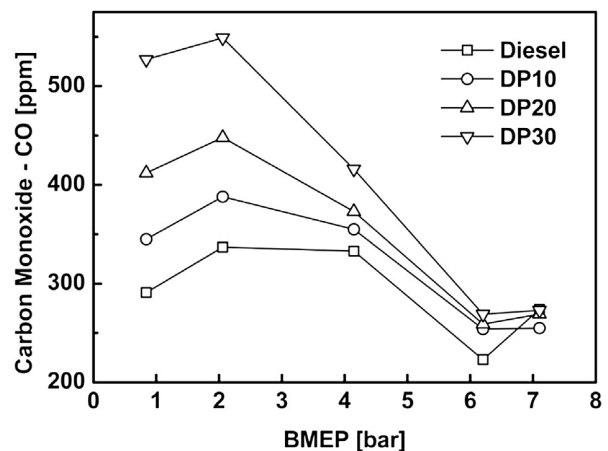

Fig. 5. Variation of carbon monoxide emissions with n-pentanol and engine load.

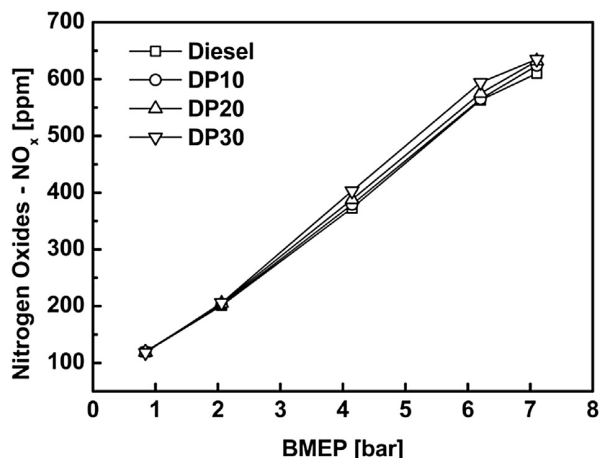

Fig. 6. Variation of nitrogen oxides emissions with n-pentanol and engine load.

pentanol/diesel blends and higher percentage of n-pentanol leads to higher NO<sub>x</sub> emissions at a given engine load. The maximum increases are 8.0, 5.5 and 4.1% at engine loads of 4.15, 6.20 and 7.10 bar, respectively. Can et al. [49] and Kass et al. [10] reported similar variations in NO<sub>x</sub> emissions for ethanol/diesel blend. In diesel engine, several factors are related to the NO<sub>x</sub> formation process for alcohols/diesel blends [20,47]. First, alcohols, like ethanol, butanol and pentanol have lower cetane number than diesel fuel, which leads to longer ignition delay. Consequently, more blend fuel is injected into the combustion chamber during the ignition delay period, resulting in more fuel being burned in the premixed combustion phase and hence elevating the in-cylinder gas temperature. Second, the oxygen content contained in n-pentanol might assist NO<sub>x</sub> formation. Finally, compared with diesel, alcohols, up to pentanol, own higher latent heat of vaporization and hence reduce the in-cylinder gas temperature with addition of alcohols. These factors counteract each other at low engine load, while the longer ignition delay associated with increasing n-pentanol leads to higher NO<sub>x</sub> emissions at high engine load.

NO<sub>2</sub> is a toxic gas which may increase the risk of respiratory symptoms and cause serious environment issues. Thus, it is of interest to examine the variations of NO<sub>2</sub> emission when n-pentanol is added into diesel fuel. Since the nitrogen oxide (NO) and nitrogen oxides (NO<sub>x</sub>) were measured in this work, the emissions of NO<sub>2</sub>, as shown in Fig. 7, can be directly obtained by subtracting NO from

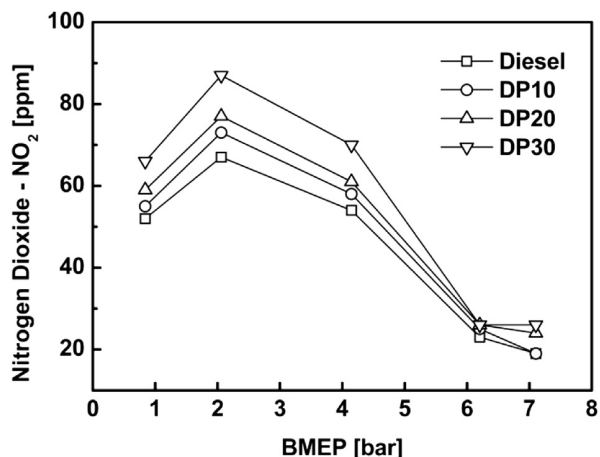

Fig. 7. Variation of nitrogen dioxides emissions with n-pentanol and engine load.

NO<sub>x</sub>. In general, NO<sub>2</sub> increases with engine load increasing from 0.84 to 2.06 bar and gradually decreases at higher engine loads for each fuel. Furthermore, with the increase of n-pentanol, the NO<sub>2</sub> emission exhibits an increasing trend at each engine load. NO<sub>2</sub> can be produced from NO promptly by the reaction (1)  $\text{NO} + \text{HO}_2 \rightarrow \text{NO}_2 + \text{OH}$ . NO<sub>2</sub> can be converted to NO by the reaction (2)  $\text{NO}_2 + \text{O} \rightarrow \text{NO} + \text{O}_2$  when the in-cylinder gas temperature is high [50]. Because of the lower in-cylinder gas temperature at low engine load, NO<sub>2</sub> produced from reaction (1) is frozen, leading to higher NO<sub>2</sub> concentration. Previous studies [47,51] reported similar finding with methanol/diesel and ethanol/diesel blends. It has been reported that the reaction (3)  $\text{CH}_2\text{OH} + \text{O}_2 \rightarrow \text{CH}_2\text{O} + \text{HO}_2$  in the oxidation of methanol yields HO<sub>2</sub> free radical, which can assist the conversion of NO to NO<sub>2</sub> through reaction (1) [52], thus, this leads to higher NO<sub>2</sub> emission for methanol/diesel blends [51]. Similarly, under high pressure and low temperature condition, the largest fraction of n-pentanol undergoes H-abstraction reactions at  $\alpha$ -carbon site to yield  $\alpha$  fuel radical  $\text{CH}_3\text{CH}_2\text{CH}_2\text{CH}_2\text{C}^\bullet\text{HOH}$ , which mostly reacts with O<sub>2</sub> to form n-pentanol and HO<sub>2</sub> radical [40], while HO<sub>2</sub> favors the conversion of NO to NO<sub>2</sub>, as shown in reaction (R1). Therefore, the same reason applies to both n-pentanol and methanol for the increase in NO<sub>2</sub> emission with increase of alcohol content in the blended fuel.

### 3.4. Particulate emissions

The variation of particulate mass concentration with n-pentanol and engine load is illustrated in Fig. 8. It can be observed that the particulate mass concentration increases with the increase of engine load, which is especially significant at high engine load. This is because that more fuel is required to achieve higher power output at high engine load and hence more fuel (and hence more carbon) is available for particulate formation while excess air ratio decreases leading to less oxygen available for soot oxidation. Moreover, as engine load increases, ignition delay becomes shorter and more fuel is injected and hence more fuel is burned during the period of diffuse combustion, resulting in a rapid increase in particulate mass concentration. Decrease in particulate mass concentration is observed with increase of n-pentanol. It is decreased by 12, 27 and 42% on average of the five engine loads for DP10, DP20 and DP30, respectively, comparing with neat diesel fuel. Similar observations were reported for other alcohols/diesel blends in the literatures [10,12,15,20,51] and the explanations offered in them can also be applied to n-pentanol/diesel blends.

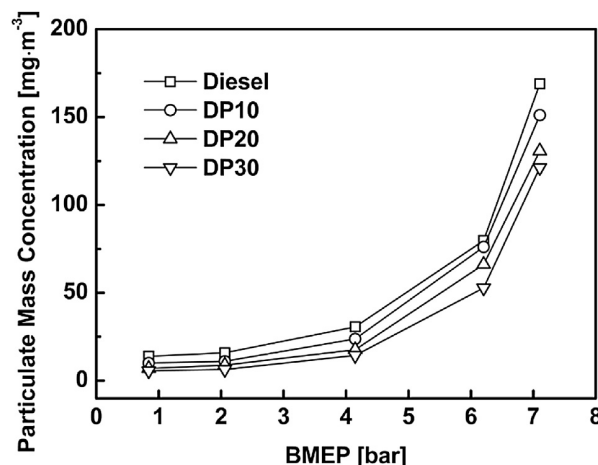

Fig. 8. Variation of particulate mass concentration with n-pentanol and engine load.

First, the oxygen atoms in the n-pentanol molecule can lower the chance of soot nuclei formation in local fuel rich zone and promote soot oxidation during diffusion combustion period, resulting in reduction of particulate emissions. Referring to Table 1, the carbon to hydrogen mass ratio of n-pentanol is lower than that of diesel fuel, leading to a decrease in C/H mass ratio with increase of n-pentanol in the blended fuel and hence less carbon is available to form particulate [5]. Third, Westbrook et al. [4] found that, through chemical kinetic modeling, the carbon atom bonded to O atom cannot make contribution to soot production in the oxygenate fuels. Thus, there is reduction in particulate mass concentration with increase of n-pentanol in the blended fuel. The

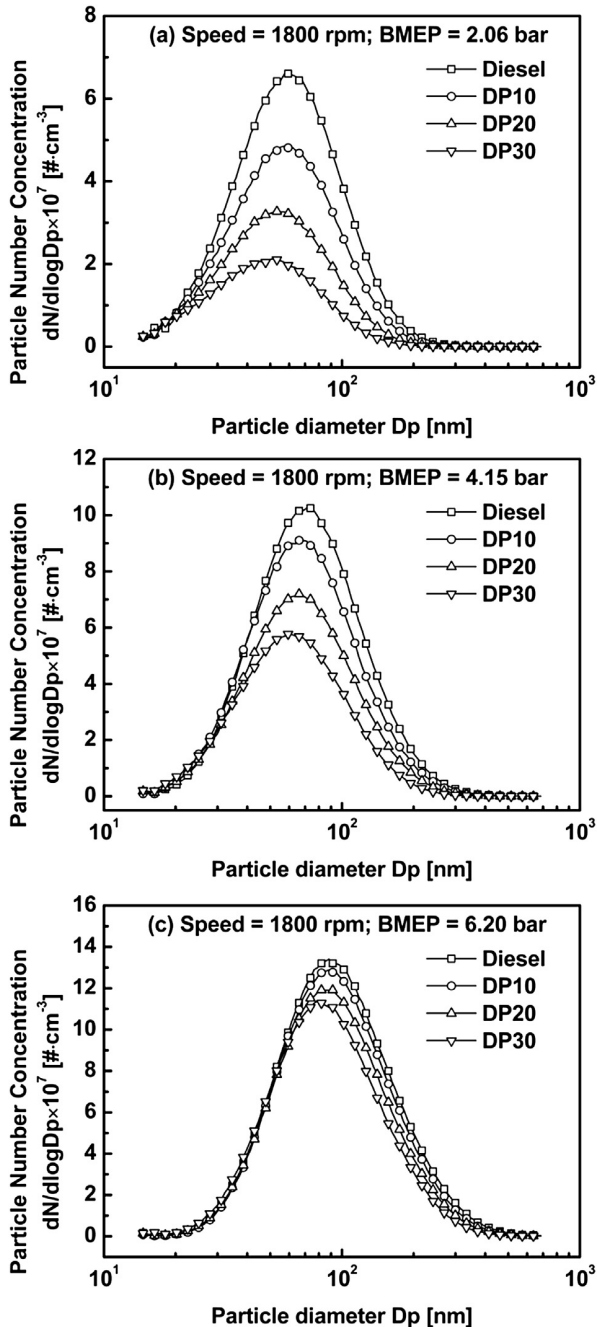

Fig. 9. Variation of particle number concentration and size distribution with n-pentanol and engine load.

Table 6

Total particle number concentration (TPNC) and geometric mean diameter (GMD) at various engine loads and fuel blends.

Fuel	2.05 bar		4.15 bar		6.20 bar	
	TPNC $\times 10^7$ [#·cm $^{-3}$ ]	GMD [nm]	TPNC $\times 10^7$ [#·cm $^{-3}$ ]	GMD [nm]	TPNC $\times 10^7$ [#·cm $^{-3}$ ]	GMD [nm]
Diesel	3.73	58.0	5.76	71.9	7.88	94.2
DP10	2.91	55.2	5.14	68.0	7.43	92.7
DP20	1.87	51.7	4.05	66.1	6.86	89.5
DP30	1.22	47.0	3.29	60.8	6.49	84.1

increased ignition delay for n-pentanol/diesel blends caused by the lower cetane number of n-pentanol is favorable for air entrainment and thus premixing, leading to lower particulate emissions as well. Furthermore, the replacement of some fraction of highly sooting aromatic and sulfur content in diesel fuel by n-pentanol also accounts for the particulate concentration reduction. However, the diesel fuel used in this work contains less than 10 mg kg $^{-1}$  sulfur, the influence of sulfur content on particulate reduction should be negligible in this work.

Fig. 9 shows the particle number-size distributions of the fuels at the BMEPs of 2.06, 4.15 and 6.20 bar, corresponding to low, medium and high engine load, respectively. Particles with size ranging from 15 to 700 nm were collected by the SMPS. It can be observed that most of the collected particles are less than 200 nm in diameter and the size distribution curves become flatter with increasing n-pentanol in the fuel, indicating that the number of particles decreases when n-pentanol is present in the diesel fuel. This is similar to the reduction in particle number concentrations with ethanol/diesel blends [15,16], as a result of oxygen contained in n-pentanol which reduces the formation of soot nuclei in locally fuel rich zone. The total particle number concentration (TPNC) and geometric mean diameter (GMD) are given in Table 6 for the three engine loads as well. One can observe that the GMD increases with increasing engine load for each fuel. This is because when more fuel is injected, the overall air/fuel ratio is reduced, in-cylinder pressure and temperature are increased, resulting in enhanced coagulation and agglomeration of particles and increased particle size [53]. This is consistent with the observation in Refs. [54,55]. Since fewer soot nuclei are produced with increase of n-pentanol, the probability of coagulation and agglomeration of the particles are reduced and hence the GMD is reduced, as shown in Table 6.

The influence of n-pentanol on the reduction in particle number concentration is most obvious at the engine load of 2.06 bar, followed by 4.15 and 6.20 bar. The corresponding reductions at these three engine loads are 22–67, 11–43 and 6–18%, respectively for different percentage of n-pentanol. Similar results were found by Zhang et al. [55] and they explained that it is a consequence of the cooling effect during the dilution process. Since the exhaust gas temperature increases with the increase of engine load and unburned hydrocarbon emissions increase with the increase of n-pentanol, the cooling effect is more obvious at higher engine load and higher percentage of n-pentanol and hence the percentage reduction in particle number concentration decreases with increase in engine load [54,55].

#### 4. Conclusions

The objective of this work is to investigate experimentally the effects of n-pentanol/diesel blends on the combustion, performance, gaseous and particulate emissions on a naturally-aspirated, four-cylinder, direct-injection diesel engine. Three n-pentanol/diesel blends, corresponding to 10%, 20% and 30% by volume of n-

pentanol in diesel fuel, and neat diesel fuel were employed and investigated at different steady engine loads. The main results are summarized as follows.

- 1) Up to 30% by volume of n-pentanol can be well mixed with diesel fuel with no solvents at room temperature and can be applied on diesel engine without any modifications.
- 2) Base on the analysis of in-cylinder pressure and heat release rate curves, the blended fuels exhibit similar curves with those of neat diesel fuel. However, addition of n-pentanol results in longer ignition delays as a result of the lower cetane number of n-pentanol. The peak of heat release rate in the premixed combustion phase increases with increase of n-pentanol due to more fuel being burned in the premixed combustion phase resulted from longer ignition delay with the addition of n-pentanol.
- 3) With an increase of n-pentanol in the blended fuel, the brake specific fuel consumption increased, due to the lower heat value of n-pentanol. But no obvious difference is observed for the brake thermal efficiency.
- 4) Concerning for gaseous emissions, HC and CO emissions exhibit similar trend. Both increased with n-pentanol at low and medium engine loads mainly caused by the lower cetane number of the blended fuels. While n-pentanol can improve the in-cylinder combustion and there is a slight decrease in HC emissions at high engine load. Slight increase is found in NO<sub>x</sub> emissions at high engine load. The influence of cooling effect counteracts the oxygen content in blend fuel and higher in-cylinder gas temperature associated with longer ignition delay, bringing about no obvious difference for NO<sub>x</sub> emissions at the low engine load. However, the longer ignition delay dominated the NO<sub>x</sub> formation at higher engine load associated with higher in-cylinder temperature. Moreover, NO<sub>2</sub> emissions are found to increase with increase in n-pentanol, caused by the –OH functional group.
- 5) n-Pentanol can reduce the particulate mass concentration and total particle number concentration simultaneously and the higher the n-pentanol, the larger is the reduction, which is associated with the reduced carbon content, leaner gas condition in the combustion chamber and longer ignition delay brought about by n-pentanol.

It can be concluded that there are increases in unburned hydrocarbon, carbon monoxide and nitrogen oxides emissions on diesel engine fueled with n-pentanol/diesel blends. However, n-pentanol has the potential to reduce both the particulate mass concentration and number concentration.

## Acknowledgment

The authors appreciate the support of The Hong Kong Polytechnic University (2013CB228406) (Project Number G-UA43), National Natural Science Foundation of China (Grant No. 51136005, 51121092) and the National Basic Research Program (2013CB228406).

## References

- [1] Demirbas A. Progress and recent trends in biofuels. *Prog Energy Combust Sci* 2007;33:1–18.
- [2] Limayem A, Ricke SC. Lignocellulosic biomass for bioethanol production: current perspectives, potential issues and future prospects. *Prog Energy Combust Sci* 2012;38:449–67.
- [3] González DMA, Piel W, Asmus T, Clark W, Garbak J, Liney E, et al. Oxygenates screening for advanced petroleum-based diesel fuels: part 2. The effect of oxygenate blending compounds on exhaust emissions. SAE; 2001. SAE paper no.: 2001-01-3632.
- [4] Westbrook CK, Pitz WJ, Curran HJ. Chemical kinetic modeling study of the effects of oxygenated hydrocarbons on soot emissions from diesel engines. *J Phys Chem A* 2006;110:6912–22.
- [5] Tree DR, Svensson KI. Soot processes in compression ignition engines. *Prog Energy Combust Sci* 2007;33:272–309.
- [6] He BQ, Wang HX, Hao JM, Yan XG, Xiao HH. A study on emission characteristics of an EFI engine with ethanol blended gasoline fuels. *Atmos Environ* 2003;37:949–57.
- [7] Yuksel F, Yuksel B. The use of ethanol–gasoline blend as a fuel in an SI engine. *Renew Energy* 2004;29:1181–91.
- [8] Bayraktar H. Experimental and theoretical investigation of using gasoline–ethanol blends in spark-ignition engines. *Renew Energy* 2005;30:1733–47.
- [9] Najafi G, Ghobadian B, Tavakoli T, Buttsworth DR, Yusaf TF, Faizollahnejad M. Performance and exhaust emissions of a gasoline engine with ethanol blended gasoline fuels using artificial neural network. *Appl Energy* 2009;86:630–9.
- [10] Kass MD, Thomas JF, Storey JM, Domingo N, Wade J, Kenreck G. Emissions from a 5.9 liter diesel engine fueled with ethanol diesel blends. SAE; 2001. SAE paper no.: 2001-01-2018.
- [11] He BQ, Shuai SJ, Wang JX, He H. The effect of ethanol blended diesel fuels on emissions from a diesel engine. *Atmos Environ* 2003;37:4965–71.
- [12] Corkwell KC, Jackson MM, Daly DT. Review of exhaust emissions of compression ignition engines operating on E diesel fuel blends. SAE; 2003. SAE paper no.: 2003-01-3283.
- [13] Li DG, Zhen H, Xingcai L, Wugao Z, Jianguang Y. Physico-chemical properties of ethanol–diesel blend fuel and its effect on performance and emissions of diesel engines. *Renew Energy* 2005;30:967–76.
- [14] Rakopoulos CD, Antonopoulos KA, Rakopoulos DC. Experimental heat release analysis and emissions of a HSDI diesel engine fueled with ethanol–diesel fuel blends. *Energy* 2007;32:1791–808.
- [15] Lapuerta M, Armas O, Herreros JM. Emissions from a diesel–bioethanol blend in an automotive diesel engine. *Fuel* 2008;87:25–31.
- [16] Di Y, Cheung CS, Huang Z. Experimental study on particulate emission of a diesel engine fueled with blended ethanol–dodecanol–diesel. *J Aerosol Sci* 2009;40:101–12.
- [17] Sarjoovara T, Alantie J, Larmi M. Ethanol dual-fuel combustion concept on heavy duty engine. *Energy* 2013;63:76–85.
- [18] Hansen AC, Zhang Q, Lyne PWL. Ethanol–diesel fuel blends—a review. *Bio-resour Technol* 2005;96:277–85.
- [19] Gerdes KR, Suppes GJ. Miscibility of ethanol in diesel fuels. *Ind Eng Chem Res* 2001;40:949–56.
- [20] Rakopoulos DC, Rakopoulos CD, Hountalas DT, Kakaras EC, Giakoumis EG, Papagiannakis RG. Investigation of the performance and emissions of bus engine operating on butanol/diesel fuel blends. *Fuel* 2010;89:2781–90.
- [21] Jin C, Yao MF, Liu HF, Lee CFF, Ji J. Progress in the production and application of n-butanol as a biofuel. *Renew Sust Energy Rev* 2011;15:4080–106.
- [22] Black G, Curran HJ, Pichon S, Simmie JM, Zhukov V. Bio-butanol: combustion properties and detailed chemical kinetic model. *Combust Flame* 2010;157:363–73.
- [23] Sarathy SM, Vranckx S, Yasunaga K, Mehl M, Oßwald P, Metcalfe WK, et al. A comprehensive chemical kinetic combustion model for the four butanol isomers. *Combust Flame* 2012;159:2028–55.
- [24] Yasunaga K, Mikajiri T, Sarathy SM, Koike T, Gillespie F, Nagy T, et al. A shock tube and chemical kinetic modeling study of the pyrolysis and oxidation of butanols. *Combust Flame* 2012;159:2028–55.
- [25] Grana R, Frassoldati A, Faravelli T, Niemann U, Ranzi E, Seiser R, et al. An experimental and kinetic modeling study of combustion of isomers of butanol. *Combust Flame* 2010;157:2137–54.
- [26] Rakopoulos CD, Dimaratos AM, Giakoumis EG, Rakopoulos DC. Investigating the emissions during acceleration of a turbocharged diesel engine operating with bio-diesel or n-butanol diesel fuel blends. *Energy* 2010;35:5173–84.
- [27] Campos-Fernández J, Arnal JM, Gómez J, Dorado MP. A comparison of performance of higher alcohols/diesel fuel blends in a diesel engine. *Appl Energy* 2012;95:267–75.
- [28] Zhang Q, Yao M, Zheng Z, Liu H, Xu J. Experimental study of n-butanol addition on performance and emissions with diesel low temperature combustion. *Energy* 2012;47:515–21.
- [29] Park SH, Cha J, Kim HJ, Lee CS. Effect of early injection strategy on spray atomization and emission reduction characteristics in bioethanol blended diesel fueled engine. *Energy* 2012;39:375–87.
- [30] Chen Z, Liu J, Han Z, Du B, Liu Y, Lee C. Study on performance and emissions of a passenger-car diesel engine fueled with butanol–diesel blends. *Energy* 2013;55:638–46.
- [31] Soloiu V, Duggan M, Harp S, Vlcek B, Williams D. PFI (port fuel injection) of n-butanol and direct injection of biodiesel to attain LTC (low-temperature combustion) for low-emissions idling in a compression engine. *Energy* 2013;52:143–54.
- [32] Zhang K, Sawaya MR, Eisenberg DS, Liao JC. Expanding metabolism for biosynthesis of nonnatural alcohols. *Proc Natl Acad Sci USA* 2008;105:20653–8.
- [33] Connor MR, Cann AF, Liao JC. 3-Methyl-1-butanol production in *Escherichia coli*: random mutagenesis and two-phase fermentation. *Appl Microbiol Biotechnol* 2010;86:1155–64.
- [34] Tseng HC. Production of pentanol in metabolically engineered *Escherichia coli*. *Mass Inst Technol*; 2011.



- [35] Togbé C, Halter F, Foucher F, Mounaim-Rousselle C, Dagaut P. Experimental and detailed kinetic modeling study of 1-pentanol oxidation in a JSR and combustion in a bomb. *Proc Combust Inst* 2011;33:367–74.
- [36] Dayma G, Togbé C, Dagaut P. Experimental and detailed kinetic modeling study of isoamyl alcohol (isopentanol) oxidation in a jet-stirred reactor at elevated pressure. *Energy Fuels* 2011;25:4986–98.
- [37] Welz O, Zador J, Savee JD, Ng MY, Meloni G, Fernandes RX, et al. Low-temperature combustion chemistry of biofuels: pathways in the initial low-temperature (550 K–750 K) oxidation chemistry of isopentanol. *Phys Chem Chem Phys* 2012;14:3112–27.
- [38] Tsujimura T, Pitz WJ, Gillespie F, Curran HJ, Weber BW, Zhang Y, et al. Development of isopentanol reaction mechanism reproducing auto-ignition character at high and low temperatures. *Energy Fuels* 2012;26:4871–86.
- [39] Tang C, Wei L, Man X, Zhang J, Huang Z, Law CK. High temperature ignition delay times of C5 primary alcohols. *Combust Flame* 2013;160:520–9.
- [40] Heufer KA, Sarathy SM, Curran HJ, Davis AC, Westbrook CK, Pitz WJ. Detailed kinetic modeling study of n-pentanol oxidation. *Energy Fuels* 2012;26:6678–85.
- [41] Gautam M, Martin DW, Carder D. Emissions characteristics of higher alcohol/gasoline blends. *Proc Inst Mech Eng A J Power Energy* 2000;214:165–82.
- [42] Gautam M, Martin DW. Combustion characteristics of higher-alcohol/gasoline blends. *Proc Inst Mech Eng A J Power Energy* 2000;214:497–511.
- [43] Campos-Fernandez J, Arnal JM, Gomez J, Lacalle N, Dorado MP. Performance tests of a diesel engine fueled with pentanol/diesel fuel blends. *Fuel* 2013;107:866–72.
- [44] Yoshimoto Y, Onodera M. Performance of a diesel engine fueled by rapeseed oil blended with oxygenated organic compounds. SAE; 2002. SAE paper no.: 2002-01-2854.
- [45] Zhu L, Cheung CS, Zhang WG, Huang Z. Combustion, performance and emission characteristics of a di diesel engine fueled with ethanol-biodiesel blends. *Fuel* 2011;90:1743–50.
- [46] Bresenham D, Reisel J, Neusen K. Spindt air-fuel ratio method generalization for oxygenated fuels. SAE; 1998. SAE paper no.: 982054.
- [47] Cheung CS, Di Y, Huang Z. Experimental investigation of regulated and unregulated emissions from a diesel engine fueled with ultralow-sulfur diesel fuel blended with ethanol and dodecanol. *Atmos Environ* 2008;42:8843–51.
- [48] Karabektas M, Hosoz M. Performance and emission characteristics of a diesel engine using isobutanol–diesel fuel blends. *Renew Energy* 2009;34:1554–9.
- [49] Can Ö, Çelikten İ, Usta N. Effects of ethanol addition on performance and emissions of a turbocharged indirect injection diesel engine running at different injection pressures. *Energy Convers Manag* 2004;45:2429–40.
- [50] Merryman EL, Levy A. Nitrogen oxide formation in flames: the roles of NO<sub>2</sub> and fuel nitrogen. In: Symposium (international) on combustion; 1975. pp. 1073–83.
- [51] Cheng CH, Cheung CS, Chan TL, Lee SC, Yao CD, Tsang KS. Comparison of emissions of a direct injection diesel engine operating on biodiesel with emulsified and fumigated methanol. *Fuel* 2008;87:1870–9.
- [52] Lyon RK, Cole JA, Kramlich JC, Chen SL. The selective reduction of SO<sub>3</sub> to SO<sub>2</sub> and the oxidation of NO to NO<sub>2</sub> by methanol. *Combust Flame* 1990;81:30–9.
- [53] Lapuerta M, Martos FJ, Herreros JM. Effect of engine operating conditions on the size of primary particles composing diesel soot agglomerates. *J Aerosol Sci* 2007;38:455–66.
- [54] Ning Z, Cheung CS, Liu SX. Experimental investigation of the effect of exhaust gas cooling on diesel particulate. *J Aerosol Sci* 2004;35:333–45.
- [55] Zhang ZH, Cheung CS, Chan TL, Yao CD. Experimental investigation of regulated and unregulated emissions from a diesel engine fueled with Euro V diesel fuel and fumigation methanol. *Atmos Environ* 2010;44:1054–61.
- [56] Lapuerta M, Garcia-Contreras R, Campos-Fernandez J, Dorado MP. Stability, lubricity, viscosity, and cold-flow properties of alcohol-diesel blends. *Energy Fuels* 2010;24:4497–502.
- [57] Abou-Rachid H, Marrouni KE, Kaliaguine S. DFT studies of the hydrogen abstraction from primary alcohols by O<sub>2</sub> in relation with cetane number data. *J Mol Struct Theochem* 2003;631:241–50.